

Government of Karnataka
Department of Technical Education
Board of Technical Examinations, Bangalore

	Course Title: MACHINE SHOP		
	Scheme (L:T:P) : 0:2:4	Total Contact Hours: 78	Course Code: 15ME46P
	Type of Course: Tutorial and practice	Credit : 03	Core/ Elective: Core(practice)
CIE- 25 Marks		SEE- 50 Marks	

Prerequisites: Theoretical concepts Machine tool Technology

Course Objectives:

1. To understand Constructional features of basic machine tools
2. To know the various Metal cutting operations and Machine tool parameters

Course Outcomes:

On successful completion of the course, the students will be able to attain CO:

Course Outcome		CL	Linked Shops	Linked PO	Teaching Hrs
CO1	Acquire skill on working of general purpose machine tools and on various manufacturing processes.	<i>U/A</i>	-	1,2,3,4,5,6,7,8,10	24
CO2	Create model by demonstrating various turning operation	<i>U/A</i>	Turning models exercises	1,2,3,4,5,6,7,8,10	12
CO3	Develop a model by demonstrating various drilling and grinding operation	<i>U/A</i>	Drilling, grinding model exercises	1,2,3,4,5,6,7,8,10	12
CO4	Create model by demonstrating various shaping operation	<i>U/A</i>	Shaper models exercises	1,2,3,4,5,6,7,8,10	24
CO5	Create model by demonstrating various Milling operation	<i>U/A</i>	Milling models exercises	1,2,3,4,5,6,7,8,10	06
				Total sessions	78

Legend: R; Remember, U: Understand A: Application

COURSE-PO ATTAINMENT MATRIX

Course	Programme Outcomes									
	1	2	3	4	5	6	7	8	9	10
MACHINE SHOP	3	3	3	3	3	3	3	3	-	3
<p><i>Level 3- Highly Addressed, Level 2-Moderately Addressed, Level 1-Low Addressed.</i> Method is to relate the level of PO with the number of hours devoted to the COs which address the given PO. If $\geq 40\%$ of classroom sessions addressing a particular PO, it is considered that PO is addressed at Level 3 If 25 to 40% of classroom sessions addressing a particular PO, it is considered that PO is addressed at Level 2 If 5 to 25% of classroom sessions addressing a particular PO, it is considered that PO is addressed at Level 1 If $< 5\%$ of classroom sessions addressing a particular PO, it is considered that PO is considered not-addressed.</p>										

COURSE CONTENT

Unit No	Unit Name	Hour
1	TURNING PRACTICE	24
2	DRILLING PRACTICE	12
3	SHAPING PRACTICE	12
4	MILLING PRACTICE	24
5	GRINDING PRACTICE	06
	Total	78

UNITI: TURNING PRACTICE 24Hrs

Demonstration and detailed explanation of Machine tools (Ordinary lathe/capstan/Turret Lathe) and work holding devices used-Description and specification of Cutting tools required for creating model-Variou Turning operations performed in Machine shop-Safety practices to be observed-Clean the machine after operation

Hands on Experience

1. Turning practice on mild steel specimen to an accuracy of ± 0.25 mm.
2. Preparing at least **ONE model** involving the following operations. Plain Turning, Step Turning, Taper Turning, Knurling, Thread cutting

UNITII: DRILLING PRACTICE 12Hrs

Demonstration and detailed explanation of Machine tools (Radial drilling Machine) and work holding devices used-Description and specification of Cutting tools required for creating

model–Various Drilling operations performed in Machine shop-Safety practices to be observed-Clean the machine after operation

Hands on Experience

1. Preparation of ONE model with two or three different sizes holes for different materials at different locations

UNITIII: SHAPING PRACTICE

12Hrs

Demonstration and detailed explanation of Machine tools (Shaper) and work holding devices used-Description and specification of Cutting tools required for creating model–Various Shaping operations performed in Machine shop-Safety practices to be observed-Clean the machine after operation

Hands on Experience

1. Preparation of ONE model with Shaping step block cut dovetail to angles 60

UNITIV: MILLING PRACTICE

24 Hrs

Demonstration and detailed explanation of Machine tools (MILLING MACHINE) and work holding devices used-Selection and specification of Cutting tools required for creating model–Various Milling operations performed in Machine shop-Safety practices to be observed-Clean the machine after operation

Hands on Experience

1. Preparation of ONE model Milling-square-hexagon, Spur gear teeth, Key way from round bars with indexing and without indexing

UNITV: GRINDING PRACTICE

06Hrs

Demonstration and detailed explanation of Machine tools (Grinding) and work holding devices used-Selection and specification of Grinding wheels required for creating model–The grinding operations performed in Machine shop-Safety practices to be observed-Clean the machine after operation

Observe on Experience

1. The Grinding Single point cutting tool for required angle



Elements of Workshop Technology (Vols. 1 and II) by Hajra Chaudhary

SUGGESTED LIST OF STUDENT ACTIVITIES

Note: the following activities or similar activities for assessing CIE (IA) for 10 marks (Any one)

1. Each student should do any one of the following type activity or any other similar activity related to the course and before conduction, get it approved from concerned Instructor and Foreman with an intimation to HOD
2. Each student should conduct different activity and no repeating should occur

1	Take the students for local Machine shop observe the Machining practices followed in the industry and submit an hand written report of 500 words
2	Ask the students to observe the Various machining operations carried out in a sample

	component and submit an hand written report of 500 words
3	Take the students for industrial visit for a nearby MSME; observe the safety practices followed and Study Various operational activities. and submit an hand written report of 500 words

Course Delivery:

The course will be delivered through Demonstration and Shop practices

Course Assessment and Evaluation Scheme:

	What		To whom	When/Where (Frequency in the course)	Max Marks	Evidence collected	Course outcomes
Direct Assessment meth	CIE	IA	Students	Activities	10	Blue Book	2,3,4,5
				Record – Average marks of graded exercises to be computed	15	Graded exercises	2,3,4,5
	SEE	End Exam		End of the course	50	Answer scripts at BTE	1,2,3,4,5
Indirect Assessment	Student Feedback on course		Students	Middle of the course		Feedback forms	1,2,3 Delivery of course
	End of Course Survey			End of the course		Questionnaires	1,2,3,4,5 Effectiveness of Delivery of instructions & Assessment Methods

- Note: 1. The activity related exercises shall be evaluated as per the Rubrics developed by the concerned department related to the course.
2. The course related graded exercises to be evaluated as per performance mentioned in SEE scheme of evaluation.

Note to IA verifier: The following documents to be verified by CIE verifier at the end of semester

1. Blue books (Activity for 10 marks)
2. Student feedback on course regarding Effectiveness of Delivery of instructions & Assessment Methods.

Scheme of Valuation for End Examination

Note: Any one model in any one practice

Serial no	Description	Marks
1	Listing of tools & operations required for performing job	05
2	Marking of job	05
3	Operation performed	15
4	Dimensional accuracy of job	15
5	Finishing of job	10
	TOTAL	50

EQUIPMENT LIST:

1. Turret and Capstan Lathes 01
2. Horizontal Milling Machine 01
3. Vertical Milling Machine 01
4. Surface Grinding Machine 01
5. Cylindrical Grinding Machine 01
6. Shaper 02
7. Planner 01
8. Radial Drilling Machine 01
9. Power tools-Drilling
10. Power tools-grinding
11. Power tools-polishing
12. Cordless screw driver

GENERAL INSTRUCTION IN WORK SHOP

1. Every student should obtain a set of instruction sheets entitled manufacturing processes Laboratory.
2. For reasons of safety, every student must come to the laboratory in shoes. It is unsafe for the students to come to the laboratory wearing garments with parts that hang about loosely. Students should preferably use half-sleeve shirts. The students should also ensure that the floor around the machine is clear and dry (not oily) to avoid slipping.
3. An apron will be issued to each student. Students not wearing an apron will not be permitted to work in the laboratory.
4. Instruments and tools will be issued from the tool room. Every student must produce his identity card for the purpose. Tools, etc. must be returned to the tool room on the same day.
5. The student should take the permission of the Lab Staff / Tutor before handling any machine.
6. The student should not lean on the machine when it is working.
7. Power to the machines will be put off 10 minutes before the end of the laboratory session to allow the students to return the tools.
8. Students are required to clear off the chips from the machine and lubricate the guides etc. at the end of the session.
9. Laboratory reports should be submitted on blue book.
10. Blue book will not be returned to the students.

MODELS FOR PRACTICE IN WORK SHOP

UNIT I: TURNING PRACTIC -24 Hrs

(NOTE: INDIVIDUAL MODEL)

1. To make the part shown in the sketch from a mild steel rod on a Lathe

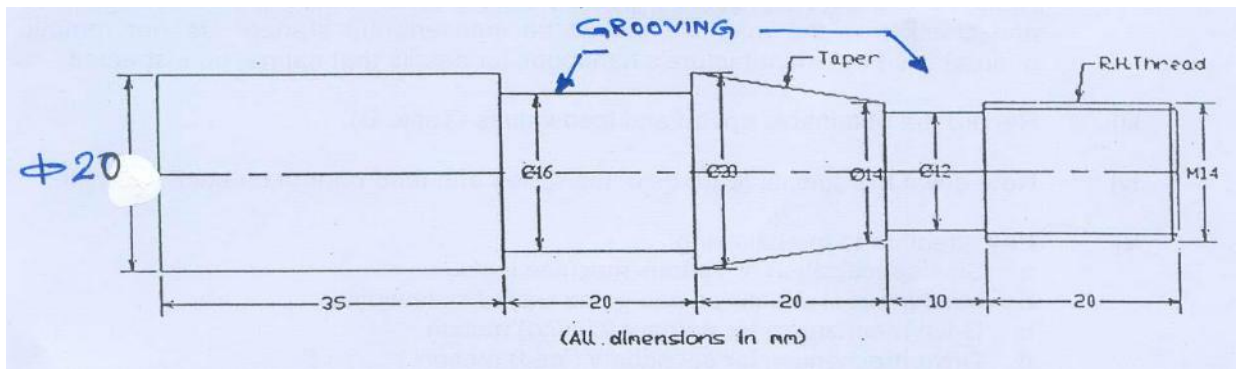

EQUIPMENT: List all tools and instruments used.

OUTLINE OF PROCEDURE

Hold the bar in a three jaw chuck and face the end with a right hand facing tool. Make central hole with a center drill. Repeat these operations for the other end of the bar. Replace the chuck by a dog plate (Center plate) and hold the job in a carrier between centers. Turn the bar to the required diameter with rough cuts. Face the steps and finishes the diameters to the required sizes. Machine the roots and the groove with form tools. Machine the taper with the help of the cross-slide swiveling arrangement. Knurl the required surface. Cut the threads.

OBSERVATIONS

- Measure all dimensions (up to second decimal place) on the specimen turned by your group. Make a neat sketch and indicate all measured dimensions.
- Discuss briefly how tapered portion was turned.
- Show the calculation of the required gear ratio for thread cutting.
- Sketch the main drive unit of the lathe and show how the speed steps are obtained.

UNIT II: DRILLING PRACTICE -12Hrs

(NOTE: INDIVIDUAL MODEL)

UNIT II: DRILLING PRACTICE

12Hrs

2. To drill, file, as shown in the sketch, out of the work piece provided and tap holes on the mild steel plate.)

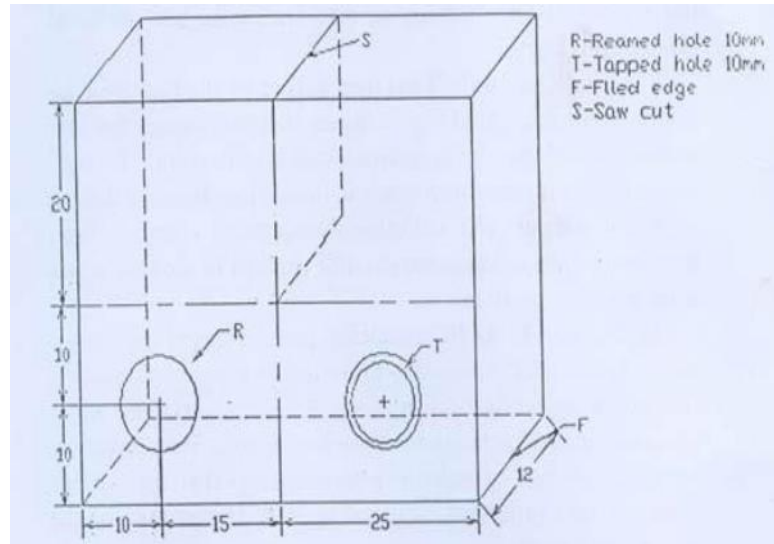

OBJECTIVE: To study the characteristic features of Drilling machine.

OUTLINE OF PROCEDURE

- i) Run the machine at low speed and observe the motions, which control the shapes of the surfaces produced. Note particularly the features, which control the geometrical form of the surface.
- ji) Learn the names of the major units and the components of each machine. Record these details (Table A). (Please ensure that the main isolator switch is off and check that the machine cannot be inadvertently started. Do not remove guards). Use the manufacture's handbook for details that cannot be inspected.
- jii) Record the obtainable speed and feed values
- iv) Note down the special features *of* the speed and feed control on each machine,
- v) Pay attention to the following:
 - a, Size specification *of* various machine tools,
 - b, Machine tool structures and guide ways I slide ways.
 - c. Drive mechanism for primary (cutting) motion,
 - d. Drive mechanism for secondary (feed) motion.

UNIT III: SHAPING PRACTICE -12Hrs
(NOTE:ONE MODEL FOR GROUP OF 05 STUDENTS)

3. To machine a V-block as shown in the sketch out of the work piece provided.

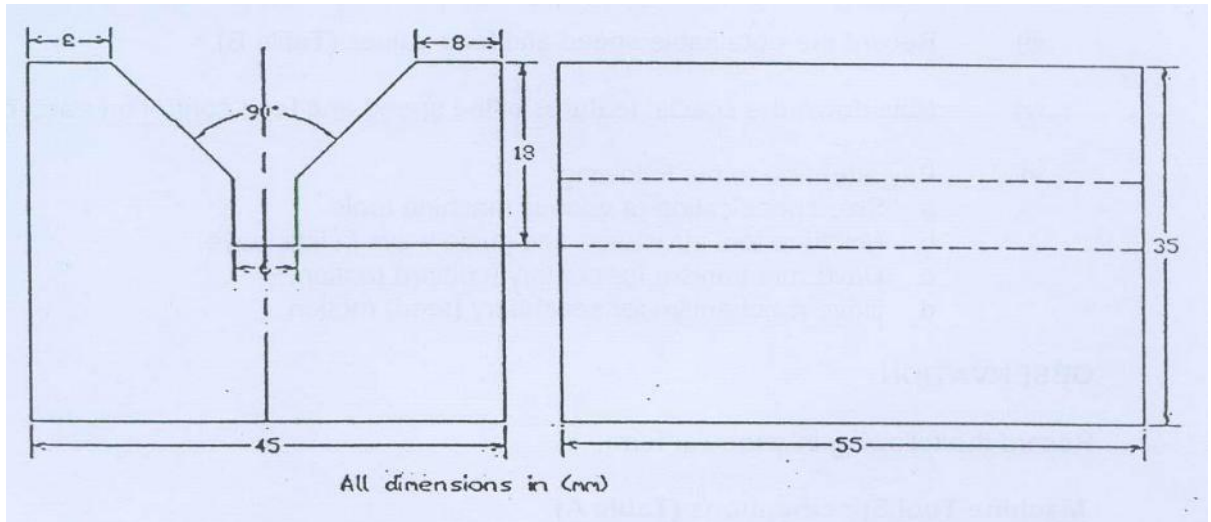

OBJECTIVE: To study the characteristic features of Shaper.

OUTLINE OF PROCEDURE

- i) Run the machine at low speed and observe the motions, which control the shapes of the surfaces produced. Note particularly the features, which control the geometrical form of the surface.
- ii) Learn the names of the major units and the components of each machine. (Please ensure that the main isolator switch is off and check that the machine cannot be inadvertently started. Do not remove guards). Use the manufacture's handbook for details that cannot be inspected.
- iii) Record the obtainable speed and feed values
- iv) Note down the special features of the speed and feed control on each machine.
- v) Pay attention to the following:
 - a. Size specification of various machine tools.
 - b. Machine tool structures and guide ways I slide ways.
 - c. Drive mechanism for primary (cutting) motion.
 - d. Drive mechanism for secondary (*feed*) motion.

OBJECTIVE: To Machine V-Block

EQUIPMENT

List all tools and instruments used.

OUTLINE OF PROCEDURE

Hold the work piece in a vice and machine the bottom surface shown in the sketch. Invert the casting in the vice and machine the top surface till the desired height is obtained. Machine the inclined faces using right and left hand tools. Finally machine the groove.

OBSERVATIONS

- (a) Measure all dimensions (up to second decimal place) on he specimen machined by your group. Make a neat sketch and indicate all measured dimensions.
- (b) Calculate the machining time *for* the bottom surface of the specimen.
- (c) Explain -the quick return mechanism.

(d) Explain the use of clapper box on the machine.

UNIT IV:MILLING PRACTICE -24 Hrs

(NOTE:ONE MODEL FOR GROUP OF 05 STUDENTS)

4. To machine the hexagonal head and the slot shown in the sketch on the specimen,

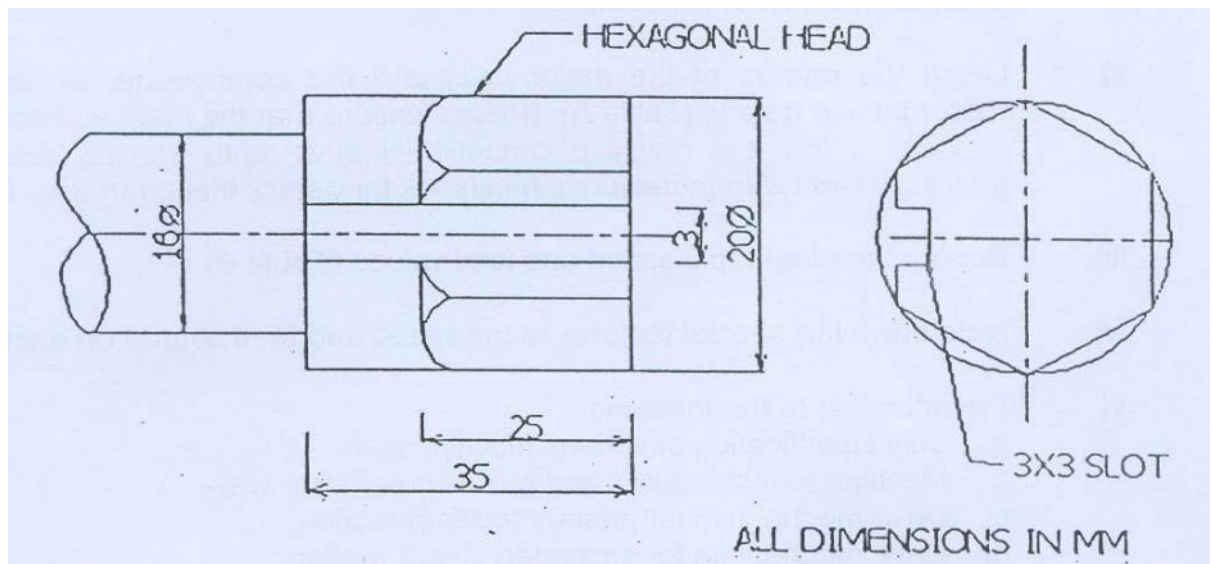

EQUIPMENT: List all tools / cutters and instruments used.

OUTLINE OF PROCEDURE

Fit the helical cutter on the arbor and the specimen between the centers of the dividing head and the tail center. Carefully adjust the work piece so that the cutter just touches the top surface of the specimen. Calculate the necessary depth of cut and then mill the six *faces* of the hexagonal head in succession. Change the cutter and mill the rectangular slot. Cut at least 2 Spur gear teeth on round rod by using milling gear teeth cutter.

OBSERVATIONS

- Measure all dimensions (up to second decimal place) on the specimen milled by your group. Make a neat sketch and indicate all measured dimensions.
- Explain in brief how the required indexing was obtained with the dividing head.
- Explain up-milling and down-milling operations. Which one did you use *for* slot milling and why?
- Explain the advantages of using a helical milling cutter.

MODEL QUESTIONS FOR FINAL EXAM

COURSE TITLE: MACHINE SHOP

TIME: 3 HOURS

MARKS:50

1. Prepare the model as per the given sketch

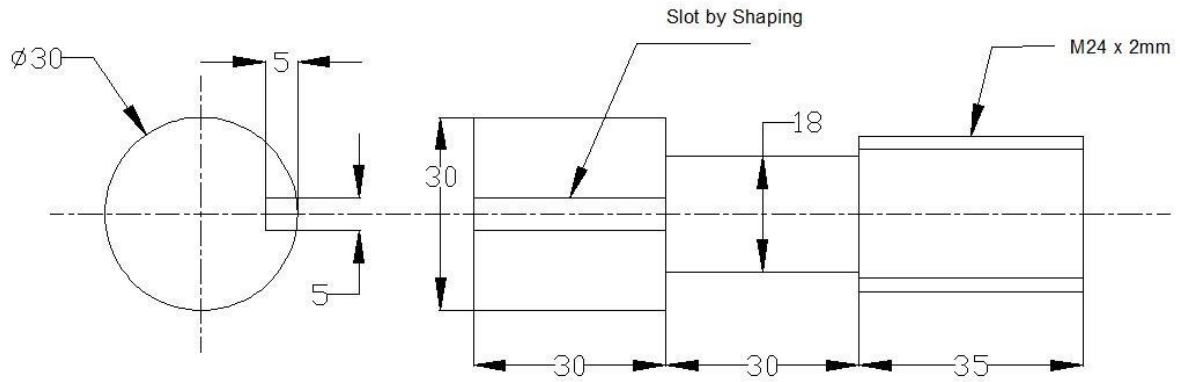

2. Prepare the model as per the given sketch

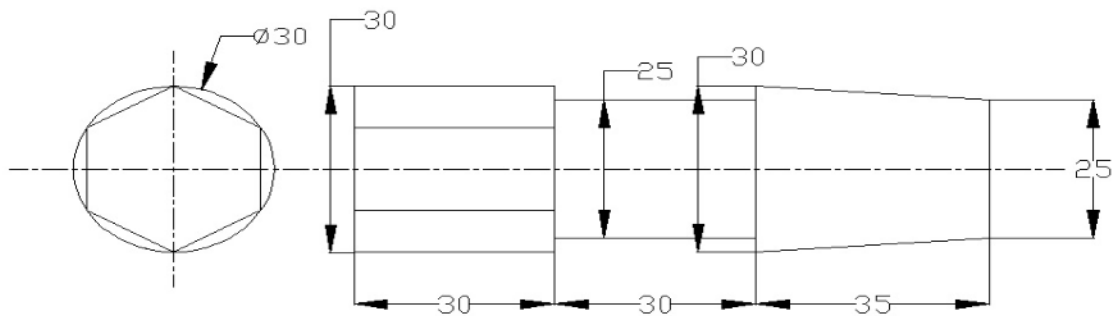

3. Prepare the model as per the given sketch

